

Vortex flow sensors with IO-Link

Universal // Smart // Easy



SIKA IO-Link vortex flow sensors

Flow measuring instruments at SIKA

SIKA has been developing and manufacturing flow measuring instruments **for more than 45 years**. Our vortex flow sensors have now been available for 12 years and have gone into **use**

millions of times since. The tried-and-tested measurement principle of the Kármán vortex trail, supplemented by IO-Link, is the **right choice for a wide range of applications**.

Data via IO-Link

In the data telegram, the values for the **flow, temperature and status information** are transferred on a cyclical basis. For example, the status information for the device notifies you whether the device is operating outside the specification, whether vibrations are detected in the system and whether the simulation mode is enabled.

Additional values can also be read out. These include the **cumulative flow rate** as well as the **minimum and maximum temperature** that the device has measured, for example.

The pulse rate of the frequency output, the **units for the flow rate** [l/min, l/h, m³/h, US gpm, US gph] and the **temperature** [°C, °F] can also be configured.

The connection of a **vibration filter** to compensate for a possible negative influence on the measured results due to mechanical vibrations in the pipeline system is also possible.

For testing purposes, the **simulation mode** can be used, in which the flow and temperature can be **adjusted and simulated on an individual basis**.



VVX vortex flow sensor in DN15, DN20 and DN25

The SIKA VVX15, VVX20 and VVX25 vortex flow sensors are made from plastic and are ideal for measuring **water** and **fluid solutions**.

The sensor convinces due to its **measuring accuracy for flow measurement** and **good price/performance ratio**. A **temperature measurement** is, of course, **integrated**.

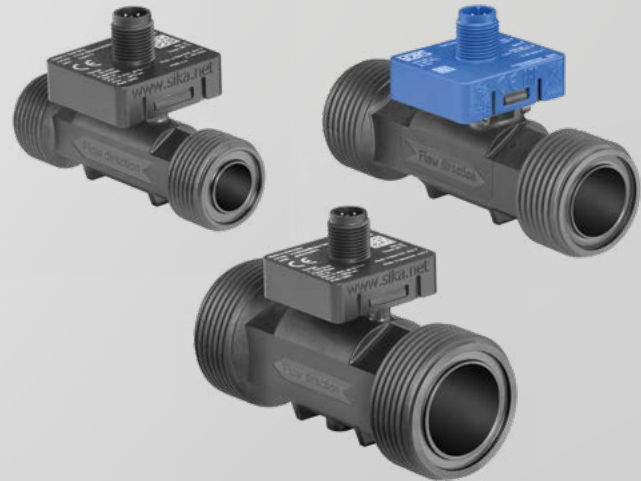

VVX vortex flow sensor in DN32 and DN40

For applications with a higher flow rate, the nominal diameters DN32 and DN40 are available. The measuring instruments are made from brass or stainless steel for the **highest resistance** and **performance**.

They are characterised by their exceptionally **rapid-response temperature measurement** and their **wide measuring range**.

Other SIKA IO-Link products

In addition to our vortex flow sensors, SIKA temperature sensors with IO-Link are also available.



Type IOM

Our robust universal temperature sensor for measuring the temperature of cooling water, lubricating oil and hydraulic oil in machines and systems.

Measuring range: -50...200 °C.



Type I03

The smallest SIKA temperature sensor with IO-Link is a genuine all-rounder: communication via IO-Link, integrated analogue- and switching output.

Measuring range: -50...120 °C.



Type IOB

Temperature sensor with standard head shape B and protection tube, ideal for retrofit measures to your system.

Measuring range: -50...200 °C.

IO-Link: Industry 4.0 pioneer

IO-Link is the innovative communication solution for the field level. The digital interface to the sensor via a standardised M12 connector and unshielded connection cable allows easy integration into your application. IO-Link complies with the international standard IEC 61131-9, is “plug & play” ready and is compatible with almost every fieldbus.

In the spirit of Industry 4.0, data from all levels of machines and systems will become available! Use the potential for completely new and better machine functions. Better and more economical systems, machines and production technologies will start with IO-Link in the future.

5 advantages of IO-Link



Reduce your costs.

Parameterizable sensors and actuators reduce the variety of the required device types. This reduces the complexity of procurement and creates space in the warehouse.



Realize innovative machine concepts.

Only the continuous communication to each sensor and actuator unlocks all functions of intelligent devices. This expands the possibilities for the development of more innovative machines and systems.



Shorten commissioning times.

IO-Link communication runs over unshielded cables and uses industry standard connectors. This saves time and reduces annoyance when replacing devices.



Increase the productivity of your machines.

IO-Link devices automatically identify and parameter each other. This simplifies the replacement of defective components and reduces downtimes of machines and plants due to repairs.



Revolutionize your maintenance.

Intelligent IO-Link devices have self-diagnosis capabilities. This enables new, predictive repair and maintenance concepts.



SIKA Dr. Siebert & Kühn GmbH & Co. KG

Struthweg 7 - 9

34260 Kaufungen / Germany

Phone +49 5605 803-0

Fax +49 5605 803-555

info@sika.net

www.sika.net